

Proposal Writer's Guide

Preparing Proposal for MAST Laboratory

MAST Laboratory Report No. MAST-16-12
December 18, 2016
Revision: 3 (October 26, 2021)

The MAST Laboratory is supported by the Department of Civil, Environmental, and Geo- Engineering, the College of Science and Engineering, and the University of Minnesota.

©2021 Regents of the University of Minnesota. All rights reserved.

The University of Minnesota is committed to the policy that all persons shall have equal access to its programs, facilities, and employment without regard to race, color, creed, religion, national origin, sex, age, marital status, disability, public assistance status, veteran status, or sexual orientation.

Contents

Contents	3
How this guide is organized	5
Contact information	5
Capabilities of the MAST system	6
System specifications.....	7
Ancillary actuators	7
Data Acquisition and Sensors	8
MAST Data Acquisition System.....	8
Krypton Coordinate Measuring Machine	8
Specimen instrumentation.....	9
Displacement sensors.....	10
Tiltmeters	10
Load cell equipment.....	10
Imaging	11
Cameras and lighting towers.....	11
Example test specimens	12
Example 1- Beam-Column or Slab-Column Joints.....	12
Example 2 - Flanged Wall	12
Example 3 - Multi-story Frame.....	13
Specimen considerations	13
Horizontal clearances.....	14
.....	14
Standard crosshead heights.....	15
Strong wall reaction system	15
Strong floor reaction system	16
Crosshead attachment	16
Strong floor/Strong Wall Attachment Plates.....	17
Project Planning and Execution	17
The Project Work Plan.....	18
Work Plan outline	18
Specimen construction, test preparation, and demolition	19
Construction space	19
Project labor	20
External contractor agreements.....	20
Training the project team	20
Available tools and equipment.....	20
Rack storage space	21
Demolition and clean-up.....	21
Recharge Rates and User Fee Policy	21
University of Minnesota business hours and calendar	22

Visit MAST Laboratory	22
Checklist.....	23
Schedule & budget considerations.....	23
Technical considerations.....	23

How this guide is organized

This guide contains information about the capabilities of the MAST system and laboratory facilities, examples of test specimens, site access policies, and budget and schedule considerations that a user preparing a proposal may find helpful.

We hope this will provide a good starting point for the proposal planning process. If you have a question that is not covered by the information in this, please feel free to contact the MAST staff.

Contact information

Evan Cosgriff, the Operations Manager, is the primary contact for questions regarding the MAST facility and equipment. Evan Cosgriff can be reached by phone at 612-626-1823 or by email at cosgriff@umn.edu.

Capabilities of the MAST system

There are two key features of the MAST system. The first is the implementation of a sophisticated six degree-of-freedom (DOF) control system to enable application of complex multi-directional deformation or loading schemes to structural subassemblages. The second is the ability to apply large loads and deformations to enable testing of large-scale structural subassemblages including portions of beam-column frame systems, walls, and bridge piers.

The MAST system employs an advanced MTS six degree-of-freedom controller to position a rigid steel crosshead using eight actuators. The six degrees of freedom in the global coordinate system of the MAST are shown in Figure 1.

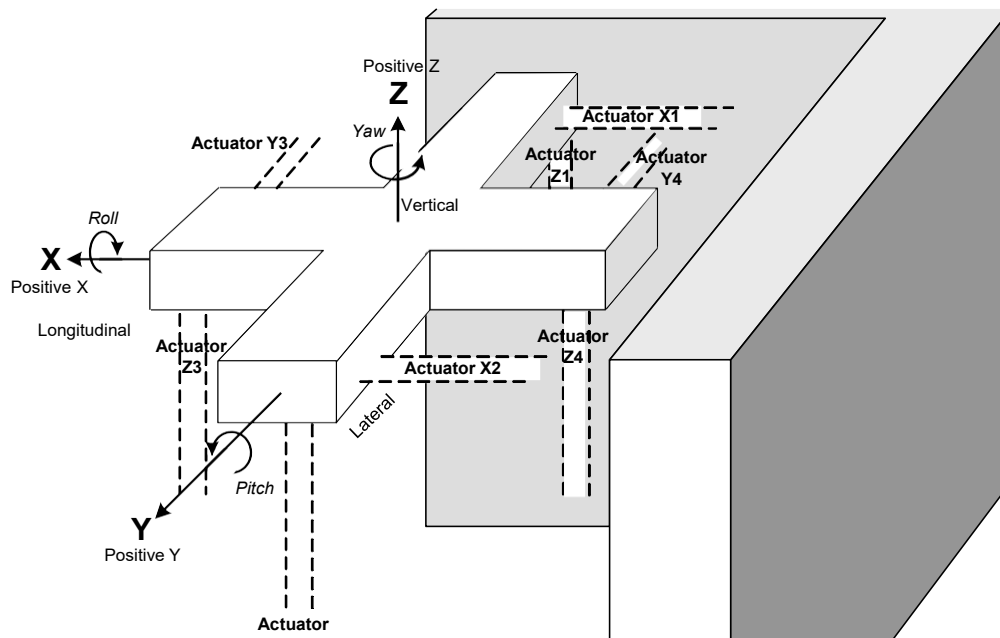

Figure 1. Oblique of crosshead positioned in strong walls

The user can specify target inputs in terms of either global position or global load. Through coordinated control of these components, the system enables control of the crosshead position as a plane in space, which makes it possible to apply triaxial control to structures such as multi-bay subassemblages or walls, or other components, as well as application of planar translations to planar substructures.

It is also possible to control the crosshead in mixed mode, setting some of the degrees of freedom in load control and others in displacement control; for example, controlling vertical force to simulate gravity while applying displacements (drifts or rotations) in the X and Y directions. DOFs can be configured in linear slaving relationships (i.e., link one DOF to another DOF) to the feedback signal of independent DOF's. For example, the moment on the test structure can be controlled as a function of the applied shear of the test specimen, which might be used to control moment-to-shear ratios on wall elements.

The typical quasi-static low-force loading rate that the MAST system can achieve is one-inch/minute.

System specifications

The maximum non-concurrent force and displacement capabilities of each DOF of the MAST system are shown in Table 1.

Table 1. Maximum non-concurrent capacities of MAST DOFs

Degree of Freedom (DOF)		Load	Stroke / Rotation
X	Translation	± 880 kips	± 16 inches
	Rotation	± 8910 kip-ft	± 7 degrees
Y	Translation	± 880 kips	± 16 inches
	Rotation	± 8910 kip-ft	± 7 degrees
Z	Translation	± 1320 kips	± 20 inches
	Rotation	± 13,200 kip-feet	± 10 degrees

Ancillary actuators

Four ±220 kip ancillary actuators with ±10-inch stroke enable further customization of testing protocols. Each of the ancillary actuators can be independently controlled by user-specified load or displacement targets, or be slaved to another ancillary actuator or DOF.

An example of using independently controlled ancillary actuators would be controlling one or more ancillary actuators to apply simulated gravity loading distributed along a floor or a test structure. An example of slaving one or more ancillary actuators to a set of scaled master drive signals is to use the ancillary actuators to apply lateral displacements (or loads) to intermediate stories of multi-story subassemblages that are proportional to those applied at the crosshead.

Brackets for connecting the ancillary actuators to the strong walls or strong floor are available. The user is responsible for providing connections between the ancillary actuators and the specimen.

Data Acquisition and Sensors

This section provides a summary of the MAST Laboratory data acquisition and instrumentation capabilities.

MAST Data Acquisition System

The MAST Data Acquisition System (DAQ) is capable of sampling 172 channels of $\pm 10V$ voltage input and 248 channels of quarter bridge 120-ohm strain gage input at rates up to 10Hz. In addition to collecting sensor data, the DAQ system also collects the DOF and ancillary actuator feedbacks (displacements and loads), shear, and warp from the analog outputs of the MTS controller.

The MAST Lab provides interconnect boxes for connecting sensors to the DAQ system. The user can decide on placement of the boxes, and will be responsible for all wiring from the sensor to the boxes. The MAST lab provides wiring from the interconnect boxes to the DAQ.

All sensor data capturing, displaying, and storing (except the Krypton CMM data) is handled by the DAQ system. Data collected from an experiment is stored on the MAST local repository. When the experiment concludes, MAST staff will assist in transferring data to a portable hard drive or the DesignSafe site (<https://www.designsafe-ci.org/>) if applicable.

Krypton Coordinate Measuring Machine

The MAST Laboratory has *one* Krypton Coordinate Measuring Machine (CMM) system. The system consists of a camera, infrared Light Emitting Diodes (LEDs), and control hardware and software. Through triangulation, the system can calculate the 3D positions of up to 128 LEDs (MAST currently has 100 LEDs) in the camera's 13.1 m³ field of view. Data sampling and archiving of the CMM system are synchronized with the DAQ system using TTL signals. The CMM system can be used to perform as-built verifications of specimens, generating metadata associated with sensor locations, and measuring 3D displacements of the structural surface. MAST staff recommends that the user not solely rely on the Krypton system and take redundant data using a different type of sensor for important data.



Figure 2. Coordinate Measuring Machine

CMM Manufacturer Specifications (units are shown in metric):

- Noise (1σ): 0.01 mm
- Field-of-view: 13.1 m³ distributed into three accuracy zones as shown in Figure 3.

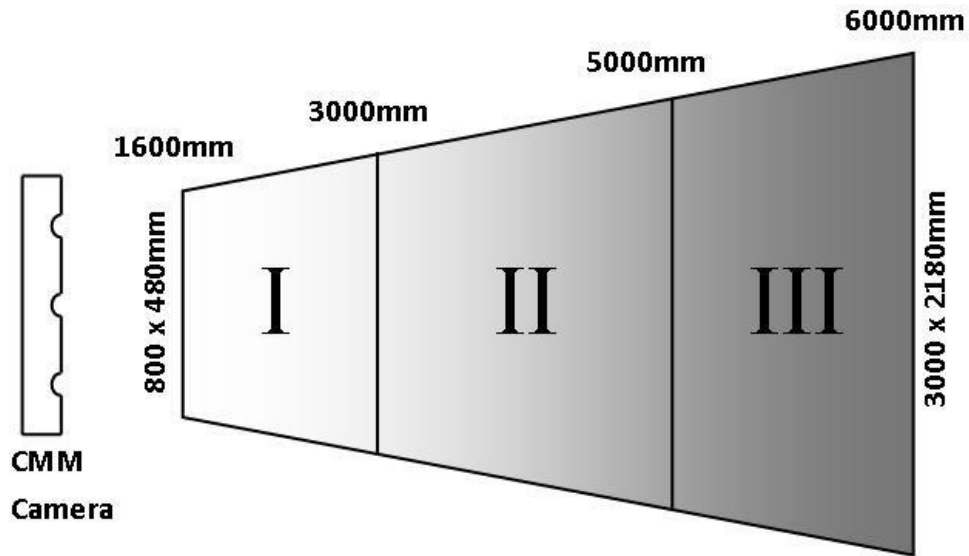

Figure 3. CMM system accuracy zones (from Krypton User Manual)

Table 2. CMM accuracy (from Krypton Manual)

Zone	Volumetric Accuracy ($\pm 2\sigma$)	Single Point Accuracy ($\pm 2\sigma$)
I	90 μ m + 10 μ m/m	60 μ m + 7 μ m/m
II	90 μ m + 25 μ m/m	60 μ m + 17 μ m/m
III	190 μ m + 25 μ m/m	130 μ m + 17 μ m/m

For more information on the Krypton CMM, please contact MAST staff.

Specimen instrumentation

The MAST Lab owns a large number of sensors available for the user, including LVDTs, string potentiometers, tiltmeters and load cells. The following section describes each of these sensors.

Project-specific calibration of any of the displacement sensors is the responsibility of the user. At the end of the testing of the final specimen, MAST staff will remove and return all laboratory-owned instrumentation and cabling.

Displacement sensors

Table 3 lists all of the Macro-Sensor LVDT's and Unimeasure string potentiometers available. The MAST Laboratory uses Schaevitz ATA-2001 LVDT conditioner units for all LVDTs.

Table 3. Quantity and types of displacement sensors available at the MAST Laboratory

Quantity: LVDT and signal conditioning	Range
6	±2.0 inches
24	±1.0 inch
30	±0.5 inches
16	±0.1 inches
Quantity: String potentiometers	Range
12	40 inches
8	30 inches
7	20 inches
17	10 inches
13	5 inches
20	3 inches
38	2 inches

Tiltmeters

The Applied Geomechanics tiltmeter units (6 available) at the MAST Laboratory meet these specifications:

- biaxial tilt measurement about two orthogonal horizontal axes when mounted on a wall
- switchable gain between ±8 degrees and ±0.8 degrees at full scale
- 1 micro radian resolution or better

Load cell equipment

The following biaxial load cell equipment for use with clevis pin fixtures is available at the Lab:

- two 1,000-kip load cells
- four 600-kip load cells
- related signal conditioners/amplifiers

The lab does not provide fixtures (i.e. clevis pins) for attaching the load cells to the test structure or reaction surface

Imaging

The MAST system provides extensive imaging capabilities to assist users in documenting experiments. This section provides an overview of MAST imaging capabilities.

Cameras and lighting towers

The MAST Laboratory provides four robotic towers that can be used to position cameras along the full height of the specimen. The towers may be adjusted to overall heights of 12, 18, or 24 feet. Each tower incorporates two shelves that can be vertically positioned independent of one another.

- Each tower shelf includes 1 x Canon SX110IS 9-megapixel still image camera with remotely controlled pan, tilt, zoom, focus, and shutter options. Cameras output to the JPEG image format. In addition, these cameras can be used to capture timelapse images during construction
- The MAST Laboratory has a Canon EOS 6D for use to take timelapse images during the course of the project.

The shelves can be easily moved vertically for positioning. Users can direct and focus the cameras and capture still images from the control room. MAST personnel install the towers in the test bay, before, during, or after specimen construction, depending upon the type of specimen and the requirements of construction. After the test is complete, MAST staff will remove the cameras, lights, and towers as demolition permits.

Example test specimens

To help plan a proposal, this section describes three potential test specimens that could be tested within the MAST system, including a slab-column joint, a multi-bay frame, and a concrete shear wall system. For more information on past projects at MAST, please contact MAST Staff. Additional information is available at <http://mastlab.umn.edu>.

Example 1 - Beam-Column or Slab-Column Joints

A slab-column joint that was tested as part of a NEESR project is shown in Figure 4. The test specimen represented a portion of a structure modeled from the foundation to the inflection point assumed to occur at midheight of the column and midspan of the floors. To represent the boundary conditions, movement of the top of the column was controlled by the MAST crosshead and the bottom end of the column was attached to the strong floor with a moment connection (in this case, a concrete base block provided by the user). Alternatively, the user could provide a universal joint for connection of the bottom half-story column to the floor to simulate the inflection point in the lower column. The four ancillary actuators were used to control the story elevation of the slab perimeter (or beam ends for a beam-column connection) while the column was subjected to a pre-defined displacement history. The MAST 6-DOF control enabled the application of complex biaxial displacement histories. In combination with mixed-mode control, the axial load on the column was controlled as well.

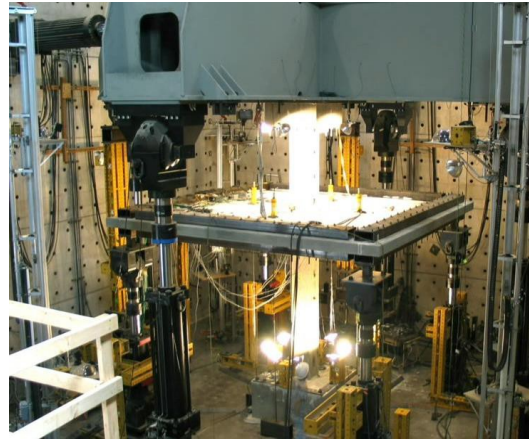

Figure 4. Slab-Column Subassembly

Example 2 - Flanged Wall

The MAST system provides the means to conduct tests to investigate the multi-directional behavior of nonrectangular wall systems. The sample reinforced concrete core wall shown in Figure 5, represents the lower four stories of a six-story prototype T-wall structure that was tested within the MAST Laboratory in Summer 2006.

The wall was subjected to prescribed bi-axial lateral drifts. At the same time, mixed-mode control imposed the desired axial load and moment-to-shear ratio at the boundaries in the two orthogonal directions.

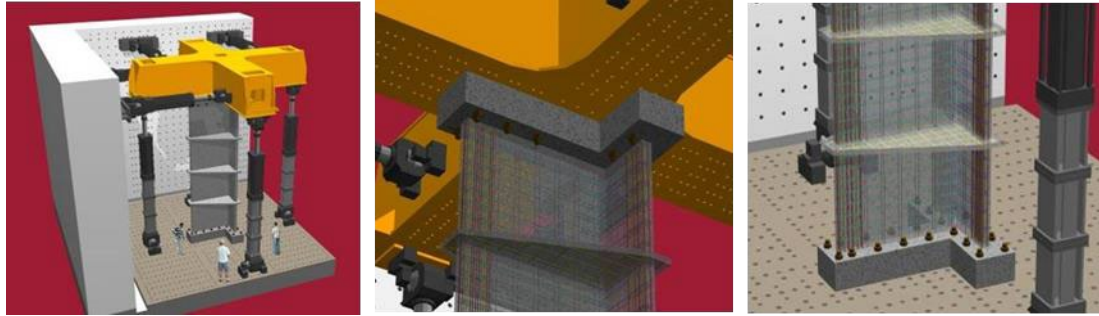

Figure 5. Schematic of 4-story T-wall test specimen

Example 3 - Multi-story Frame

The multi-directional testing capabilities of the MAST system makes it possible to test a variety of multi-story multi-bay two- or three-dimensional structural frames. Examples of possible test frame configurations are shown in Figure 6. The figure also introduces different concepts for using the ancillary actuators to provide supplemental lateral loads at the individual intermediate story levels or supplemental gravity loads to the floor systems.

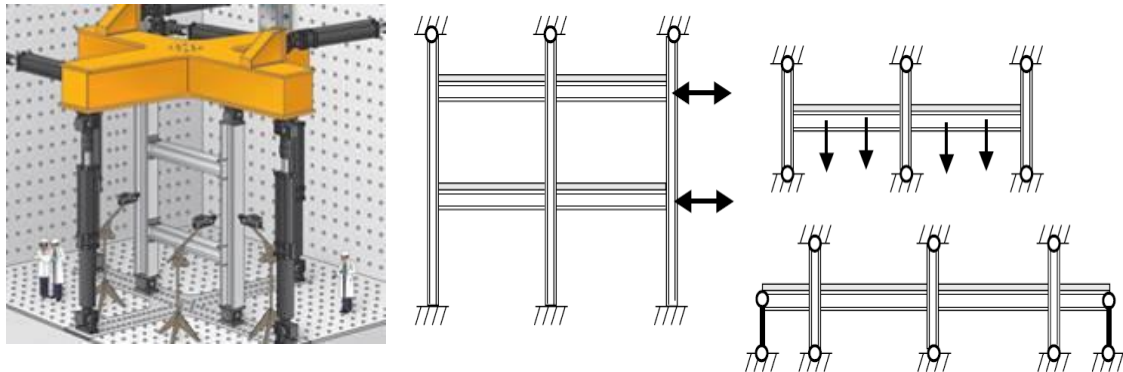

Figure 6. Examples of Multi-story Multi-bay Frames

Specimen considerations

Although the MAST system is very flexible at accommodating test specimens of various sizes with various simulated boundary conditions, several parameters must be considered when designing the specimens. These parameters are outlined in the following sections.

Horizontal clearances

The clear horizontal distance between vertical actuators can accommodate specimens up to 20 feet in length in the two primary orthogonal directions. To increase the horizontal clearance limitations by several feet, it is possible to orient a test specimen along a diagonal.

Figure 7 shows available working space in the strong floor area. The shaded areas represent potential interference with the movements of the vertical actuators.

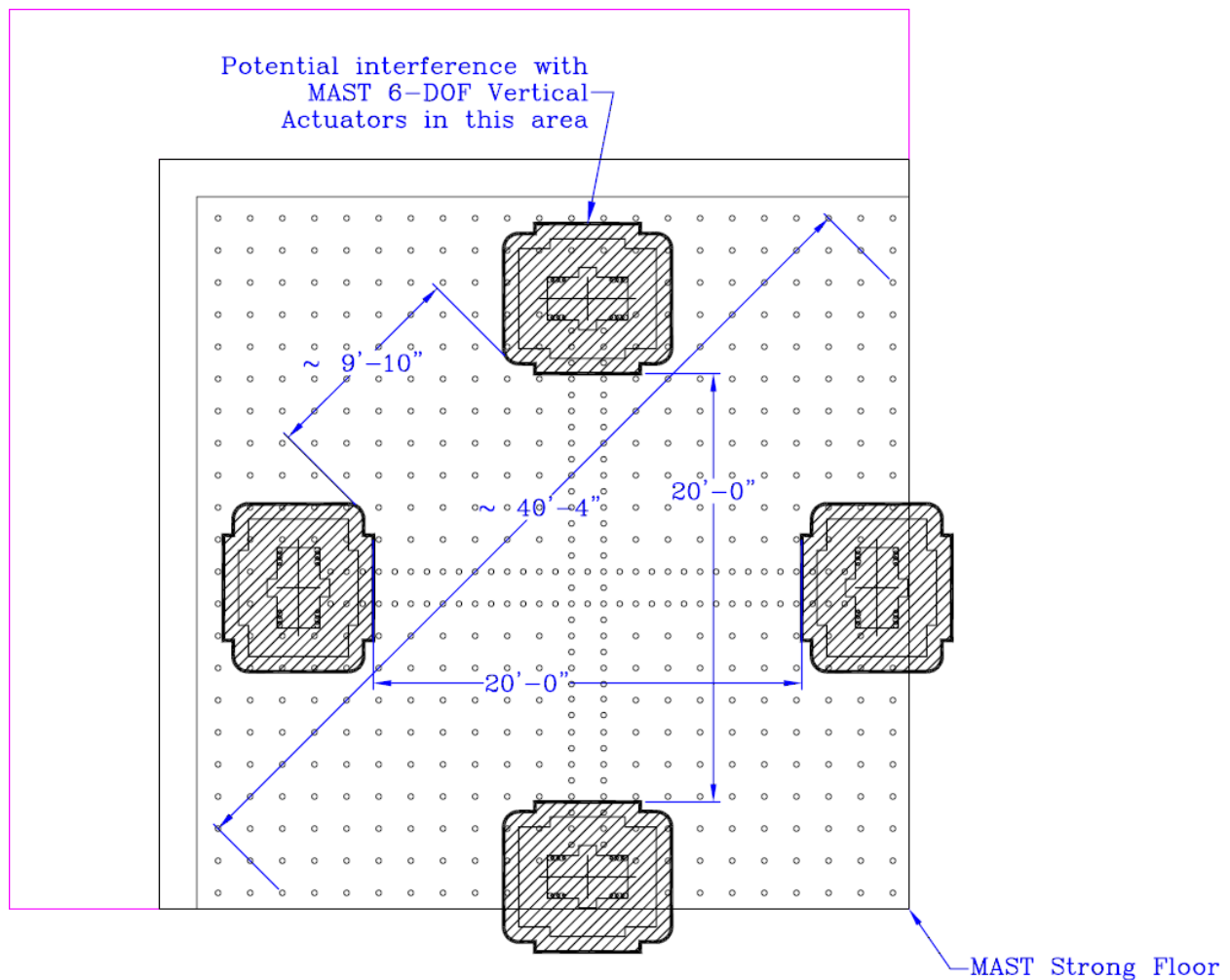

Figure 7. Strong floor interference and working space

Standard crosshead heights

Maximum vertical clearance of 28.75 feet is limited by the height of the L-shaped reaction walls to which the lateral and longitudinal actuators attach. Other standard crosshead heights are available by repositioning the horizontal actuator attachments and removing spacers from the vertical actuator assemblies. Standard dimensions between the strong floor and the bottom of the crosshead start at 18.25 feet and go to 28.75 feet in 1.5 foot increments. Figure 8 illustrates the standard crosshead positions. At each standard position, the vertical actuators are at mid-stroke to provide flexibility for actuator extension or contraction.

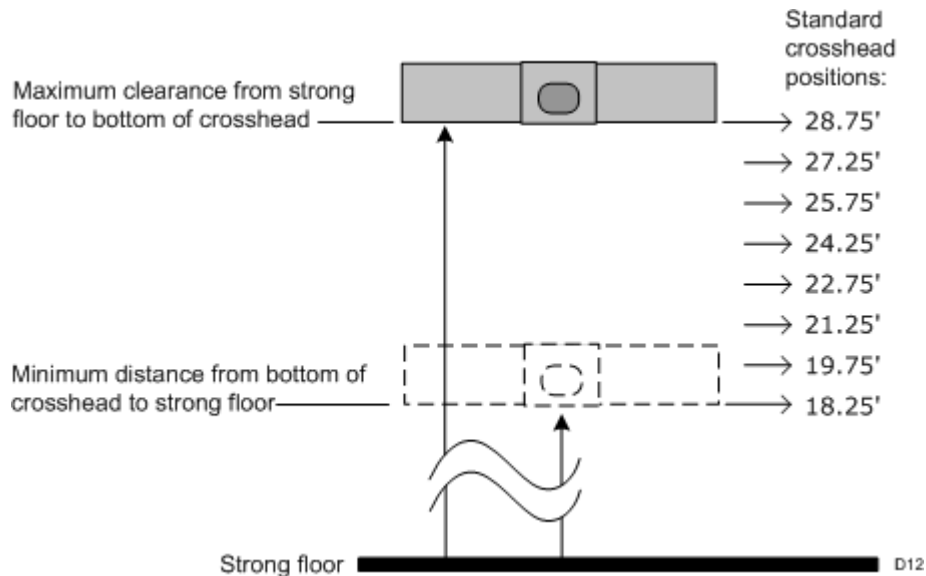

Figure 8. Standard positions of crosshead

Strong wall reaction system

The MAST Laboratory strong walls are L-shaped in plan. Each leg is 35 feet high, 35 feet wide, and seven feet thick.

The overall load capacities at the base of the wall are:

- out-of-plane (horizontal) shear equal to 1760 kips
- out-of-plane moment equal to 43,600 kip-ft
- vertical torsion equal to 38,000 kip-ft

Maximum horizontal deflection design limit for the walls is ± 0.5 inches.

Each wall has a regular grid of through-holes with nominal 18-inch spacing, center-to-center. Each three-inch unthreaded through hole has combined loading capacity of ± 125 kip normal to the wall face and 125-kip shear.

When ancillary actuators are used and attached to the walls, preliminary load demands on the strong wall should be assessed by the user during the proposal writing process. More refined calculations can be made during the Workplan process.

Strong floor reaction system

The MAST strong floor is a 7.5 ft thick, solid concrete slab on piles, covered with a 5.5-inch-thick steel plate forming the tie-down surface.

The three-inch threaded tie-down holes have combined loading capacity of ± 125 kip normal to the floor face and 125 kip shear. For purposes of proposal writing, limit combined distributed force on the strong floor to 148 kip/ft^2 normal to the floor face and 148 kip/ft^2 shear. Detailed assessment of floor stresses will be necessary during the Work Plan process. The strong floor is post-tensioned to minimize deflection.

The hole spacing on the floor is on an 18" square pattern, with additional holes spaced at 9" directly under the crosshead.

Crosshead attachment

Load demands on the MAST crosshead due to specimen attachments are determined for each experiment. In general, the following guidelines will reduce potential problems with crosshead connections.

- When possible, specimens attached to the underside of the crosshead should span the 4.5 ft by 4.5 ft central box of the crosshead. For specimens that cannot span this distance, MAST provides a stiffening plate to reduce the localized effects of the point load on the crosshead.
- Specimens put into compression will have fewer crosshead attachment issues than those put into pure shear or shear/tension forces.
- Specimens that are placed diagonally to the crosshead may require large spreader systems (provided by the user) to be attached between the crosshead arms. The specimen then attaches to these diagonal spreader frames.
- Masonry specimens generally require concrete footers and headers with reinforcing to provide shear capacity at the crosshead interface.

Non-threaded, $1 \frac{5}{8}$ " holes are drilled into the bottom plate of the crosshead. Access is provided to the inside of the crosshead for tightening bolts. The nominal hole pattern on the underside of the crosshead is shown in Figure 9.

The four-hole tabs at the side of the vertical actuator attachment sites are not intended for specimen use.

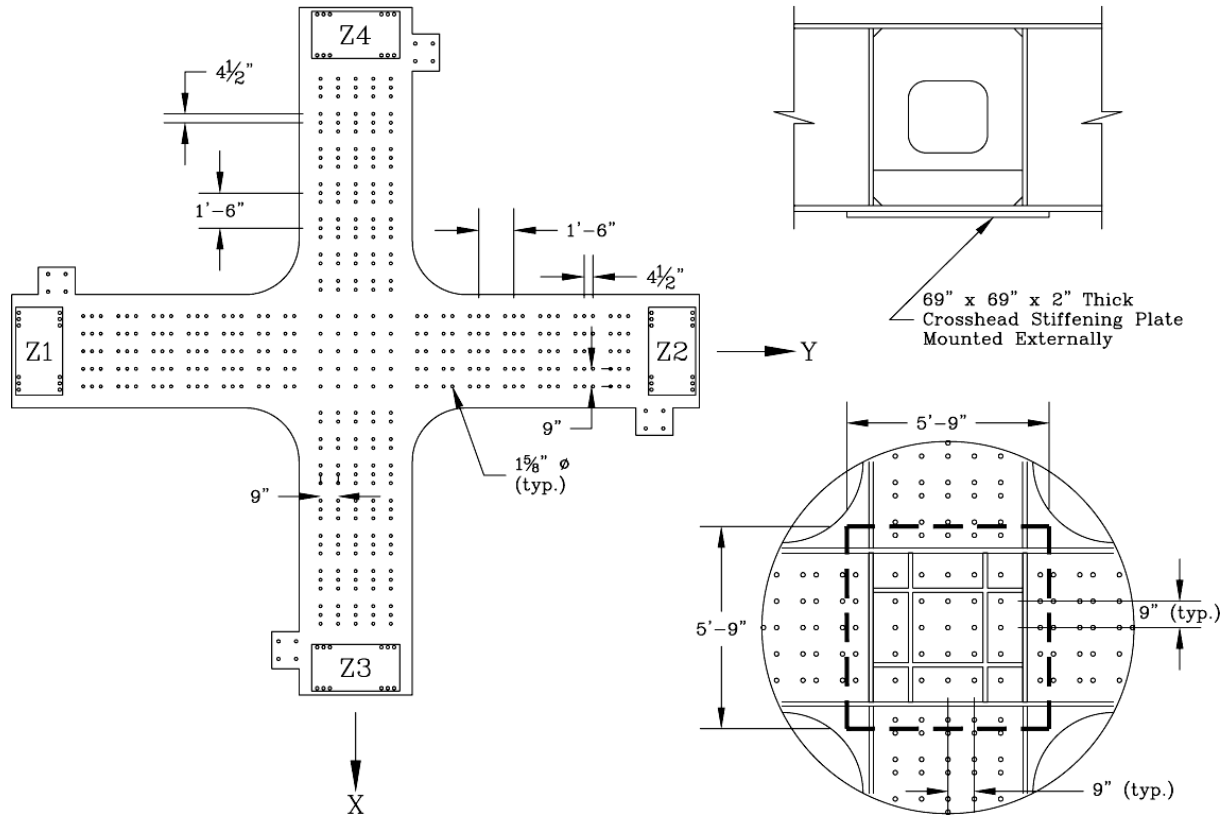

Crosshead Attachment Hole Layout

Crosshead Stiffening Plate Details

Figure 9. Pattern of attachment holes on crosshead bottom flange

Strong floor/Strong Wall Attachment Plates

MAST has four 48"x48"x4" steel transfer plates that can be used for specimen attachment to the strong floor or strong walls and have a nominal capacity of 1000-kips normal to the plate and a shear capacity of 1000-kips. The plates are attached to the strong floor or strong wall and the specimens connect to the plates via the 1"-diameter threaded holes. Figure 10 details the plate layout and dimensions.

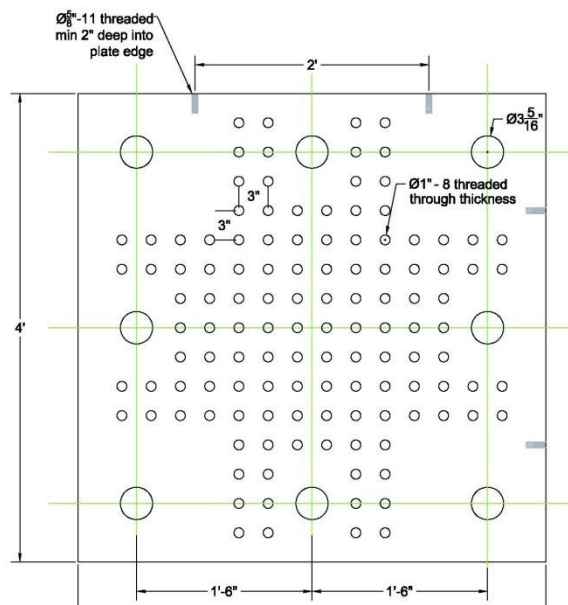

Figure 10. Strong floor/Strong Wall attachment plates

Project Planning and Execution

This section describes important aspects of planning and executing experiments at the MAST Laboratory that will affect the project schedule and project budget. As soon as the user has confirmed their funding, the user and MAST Staff must reach an agreement on the project duration and preliminary schedule, prior to executing a contract between the user and the University of Minnesota (External Sales Office).

The Project Work Plan

The key to safe and efficient use of the MAST lab is the project Work Plan. Prior to gaining access to the lab, the Principle Investigator must develop a detailed Work Plan and project schedule, and have it approved by the MAST Operations Manager. The Work Plan is the master document outlining the project for the duration of laboratory use. One of the purposes of the work plan is for the user and the MAST Operations Manager to ensure that the PIs vision of the project is realized.

After approval of the Work Plan and Schedule, the user will be allowed access to MAST Lab depending upon availability. It is recommended that a minimum of four months be allowed from submittal of the initial draft Work Plan.

Work Plan outline

The Work Plan outline identifies specific tasks, both primary and secondary, related to project activities at MAST and aids in developing a project schedule. This information will also be used to develop a formal Work Plan, identify tasks that require submittal of procedural documents (task plans), and set dates for task plan review. Ultimately, the Work Plan will include detailed descriptions of each of the following items for each test specimen:

- Project summary and critical information
- Specimen and other component drawings
- Information, documents and drawings required from MAST
- Data management plan
- Risk management and hazard identification plan
- Construction activities
- MAST detailed specimen rigging/moving plan (developed by MAST staff with user input)
- Instrumentation and DAQ plan
- Imaging plan
- Specimen displacement/loading plan
- Post-test investigations (if needed), demolition and cleanup activities (developed by MAST staff with User input)

Specimen construction, test preparation, and demolition

As many aspects of the specimen preparation and construction could affect a research project's schedule and budget, proposal submitters are encouraged to think about the likely construction process. This section outlines specimen construction related information at the MAST Laboratory that may be helpful for proposal planning.

Construction space

Depending upon the type of project, scheduling constraints, and the specimen being investigated, construction or assembly may take place in the staging area, the Test Bay, or if the User chooses, at an offsite location (e.g. the user's home laboratory, a fabrication yard, or other location). If construction occurs at an offsite location, MAST may be able to provide, for a fee, equipment such as rigging or tensioning hardware for shipping purposes.

MAST staff will assist users in developing a rigging/moving plan for repositioning test specimens in the Lab.

The Staging area is approximately 35 ft by 35 ft, as shown in the floor plan below. The Strong Floor and Test Bay is 35 ft by 35 ft, shown within dotted lines.

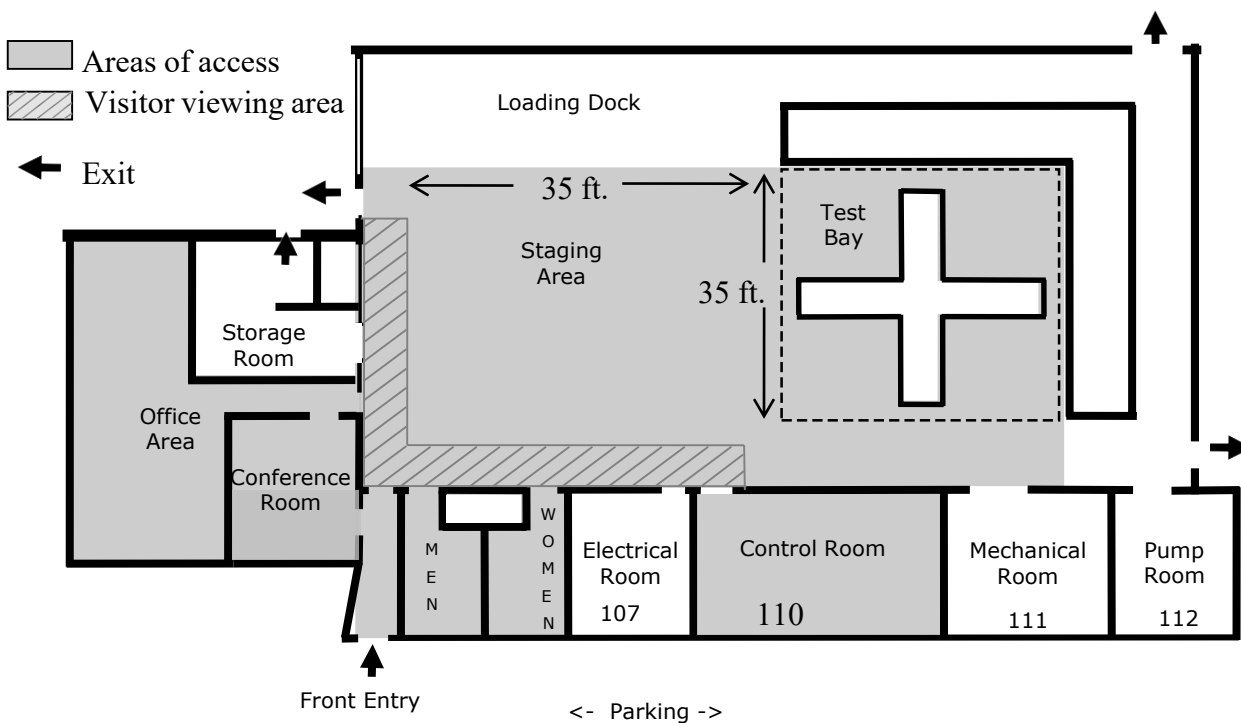

Figure 10. Floor plan of MAST Laboratory showing areas of access

The locations of the camera and lighting towers will need to be planned. MAST staff will consult with the user about where to install the cameras and lighting. Some specimen design may require that a tower be installed during construction rather than after.

Project labor

The available labor force should be considered in developing the project schedule and budget. Project labor for construction, instrumentation and other test preparation may include any of the following:

- the user provides staffing that may include technicians, graduate students and undergraduate students from their home institution
- the user may hire contractors
- U of MN undergraduates are available (a recharge is associated with this option)

MAST recommends providing 100 hours of labor per week during the time a project is using the Lab, in order to make reasonable progress. Most projects that have used the MAST Laboratory have sent personnel to reside in Minnesota during the construction and testing phases, and have hired Minnesota undergraduate students to work with the user. The undergraduate labor rate is \$16/hour.

External contractor agreements

Depending on the project schedule and budget, subcontractors may perform portions of the work associated with a project. Contractors whose services are secured directly by the User will be subject to the access limitations placed on the User by the agreement between the user and the University of Minnesota. Details concerning the oversight of subcontractors will be contained in the agreement between the University of Minnesota and the User

Training the project team

The MAST Laboratory requires that all students, employees, and others who will be working at the Lab take part in a lab safety and awareness training session. MAST staff will provide training for project personnel on general lab operations, construction, and instrumentation as needed by the project.

Available tools and equipment

The MAST Lab owns hand tools, power tools and construction equipment that are available for User use. Major equipment is listed below. Please contact MAST staff for a complete list of tools, or to check availability of a specific item.

- a wide range of hand tools including hammers, screwdrivers, wire cutters and strippers, standard wrenches and torque wrenches, a torque multiplier, etc.
- power tools including a circular saw, band saw, miter-saw, cut-off saw, grinders, a magnetic drill, hand drills, Hilti construction drill, etc.
- pneumatic tools including an impact wrench, chipping hammer and jackhammers
- Lincoln DC600 electric welder with a dual wire feed unit and arc-gouging
- Capacitor discharge welder for attaching studs for instrument brackets
- oxy-acetylene cutting torch

- a frame scaffolding system, with components to build nine 5ft tall levels of 5 ft wide by 7 ft long by frames
- three scissor lifts with a working height of varying from 19ft to 36ft.
- EFCO Super Stud framing members
- 1.25 yd³ concrete bucket
- Hilti D-200 core machine

Use of any tool or equipment in the MAST lab is subject to the guidelines specified in the MAST site access and safety policies.

The MAST Lab does not provide equipment for batching or mixing concrete. Concrete cylinder, steel coupon, and other material testing is available at the U of MN Theodore V Galambos Structural Engineering Lab, subject to a recharge fee.

Rack storage space

Rack storage space is available. The amount of space available is dependent on the number of projects in the lab.

Demolition and clean-up

After testing of the final specimen is complete, the user is responsible for demolition and removal of the specimen. Sensors provided by MAST must be removed prior to demolition.

There are several labor options for demolition and removal of the specimen:

- experienced contractors (part of project budget)
- team of U of MN undergraduates (recharge applies)
- the user can supply personnel. The work must be done with MAST staff on hand who are qualified to operate the crane and other needed lab equipment.

Recharge Rates and User Fee Policy

Prior to initiating work at the MAST Laboratory, a contract must be executed between the user and the University of Minnesota (External Sales Office) detailing project duration, lab rates, and payment schedule. Lab rates will be based on the length of time that the lab will be occupied, the anticipated effort by MAST staff, material and supply costs, maintenance costs for the MAST system and lab equipment, as well as University overhead and administrative costs. Time required for project preparation activities, such as repositioning the crosshead, will be reflected in the contract costs.

The user is responsible for costs associated with specimen construction, material and items related to the project, debris removal, and the use of any equipment or testing services in the Department of Civil, Environmental, and Geo- Engineering Structures Laboratory (located in the Civil Engineering Building).

University of Minnesota business hours and calendar

Project schedules for the MAST Lab are based on a conventional 5-day work week. Work shall not be conducted in the MAST Laboratory after hours or during official University of Minnesota holidays without prior approval of the Operations Manager. Official University of Minnesota holidays can be found at <http://www.umn.edu>.

Visit MAST Laboratory

Scheduled visits to the MAST Laboratory prior to the approval of Work Plans are welcome.

Access to the MAST Laboratory for the project period defined in the Work Plan will be provided by card keys. Visiting graduate students will be issued a University of Minnesota ID for use during their stay.

For visitor information please contact MAST staff.

Minnesota usually has cold winters and occasional hot weeks in summers. Springs and falls are usually mild, but temperature can vary quite quickly on a daily basis. The winters are snowy with on average 45.8 inches annually.

The year's average daily temperatures (°F) for central Minnesota:

Jan	Feb	Mar	Apr	May	Jun	Jul	Aug	Sep	Oct	Nov	Dec
11.8	17.9	31.0	46.4	58.5	68.2	73.6	70.5	60.5	48	33.2	17.9

Checklist

Schedule & budget considerations

- Project Work Plan development
- Specimen fabrication costs*
- Expendable items such as connection rod, nut, bolts, etc.*
- Location of specimen construction (construct specimen at MAST Lab or user's site) may include additional budget line items such as shipping costs or specialty contractor (rigging and millwright) services
- Cost and schedule implications of selected project labor (contractors, user's personnel, or U of Mn Undergraduate Students)
- Specimen demolition requirements

Technical considerations

- Specimen fits within geometric constraints of the MAST system
- Loads & displacements are within MAST capabilities
- Attachment method to connect specimen to fixtures and MAST crosshead